

How to perform complete wind measurements

Dipl.-Ing. Henning Krebs (*), Dipl.-Met. Eik Steinbach (*), Walter Wilmers (**)
(*) Ingenieurbüro Kuntzsch GmbH, Moritzburger Weg 67, D-01109 Dresden,
Tel. ++49-351/885071, Fax ++49-351/88507409, e-mail: gutachten@ib-kuntzsch.de
(**) Wilmers Messtechnik GmbH, Hirschgraben 24, D-22089 Hamburg,
Tel. ++49-40/75660898, Fax ++49-40/75660899, e-mail: wwilmers@wilmers.com

Summary

Exact and interpretable measured time rows without any gaps are the desirable result of wind measurements for the purpose of investigation or verification of the wind resource. The present paper describes measures for the avoidance of data losses or for its limitation to an acceptable extent. Moreover the extend of information is discussed that is needed besides the pure measurement results and represents a complete documentation of a wind measurement.

Keywords: wind measurement, completeness, error classification, reliability, failure resistance, data logger, documentation

1 Preface: what means complete?

Actually, it does not seem to be a very complex task to perform a wind measurement: a measurement mast equipped with sensors appropriate to the measurement's purpose is erected, the results are collected for a pre-defined period of time, afterwards the measurement set-up is dismantled, and finally the results are interpreted and evaluated. Detailed instructions for the selection, calibration and installation of the sensors as well as for the design of masts, traverses/booms are provided in the corresponding technical rules and standards (e.g. [1], [2]). So, an accuracy of the measurement that is suitable to its purpose can be achieved by following these standards. However, reliability of the measurement system and usability of its results are defining additional requirements.

As the measurement results are usually made available for different involved parties, a complete measurement (in the sense of the present paper) is only given, if the information relevant for the wind climate during the measurement period can be reconstructed from the results, even after the end of the measurement period.

Apart from data rows that should be as complete as possible, additional technical and site related information is needed for the time row's interpretation (Fig. 1).

How can completeness be measured? For time rows, the availability of the data channels characterizes their completeness, i.e. the fraction of interpretable data to the extension of data that would have been theoretical possible during the measurement period. However, the completeness of the documentation is harder to express due to the manifold character of the information. Comparison to standards (see section 4.) by means of checklists gives a gauge for the description of the documentation's quality.

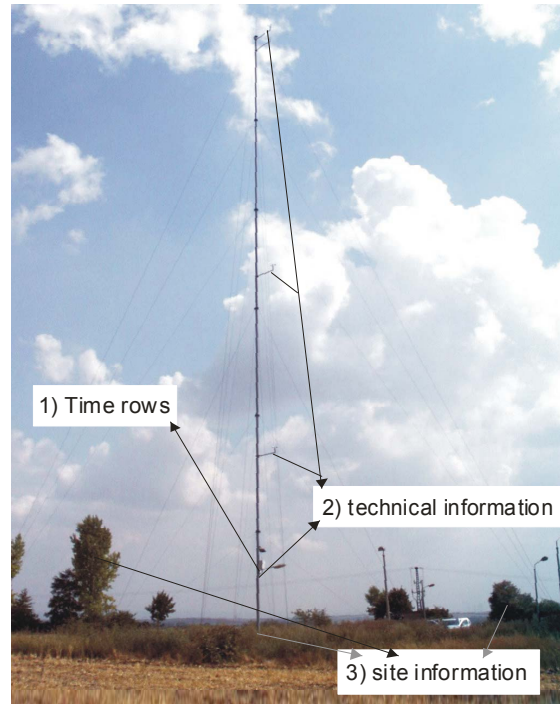

Figure 1: Information relevant for the documentation of wind measurements

2 Causes for incomplete wind measurements

Complete wind measurements can be achieved by preventing gaps in the data rows and the documentation, too. What are the reasons for these gaps? An analysis was carried out using information collected during wind measurements operated or evaluated by Ingenieurbüro Kuntzsch GmbH. The overall duration of these measurements exceeds 150 years. Main attention was paid to the manifold reasons for the occurrence of gaps in time rows.

First, the reasons were classified as shown in table 1:

error group	affected parts		kind of error	error code
technical	sensors	anemometer	electronical error	1a
			heaviness (temporary blockage of sensor due to damage of bearing)	1b
			icing	1c
		wind vane	electronical error	1d
			heaviness	1e
			icing	1f
	other equipment	wires	damaged	2a
		overload protection	damaged	2b
	data logger	parametrisation	wrong	3a
		memory	damaged	3b
			other electronical errors	3c
	power supply	battery	damaged	4a
		charge controller	damaged	4b
		solar panel	damaged	4c
		grid	power breakdown	4d
data download / transfer	parametrisation	wrong	5a	
	modem	damaged	5b	
	radio contact	(partly) lost	5c	
human / organisational			layout error	
			mounting error	
			service error	
			operation error	
			communication error	
			vandalism	
environmental			radio contact	
			icing	
			lightning	
			storm	

Table1: Error classification

Mostly, the errors classes listed in the table cause gaps in data rows only when occurring in combination with each other.

For example, wrong logger parametrisation can create gaps in time rows. This kind of error is generally human caused, but it would be imaginable, that a logger would create a warning against implausible inputs. Figure 2 shows the effect of wrong parametrisation (pink and blue curve): the recorded wind speed exceeds the values range of the logger and is cut. The effect of the error is marked with red arrows. The error code in the title, written in brackets, corresponds to the error code in table 1. All three curves were result of a measurement with the same anemometer.

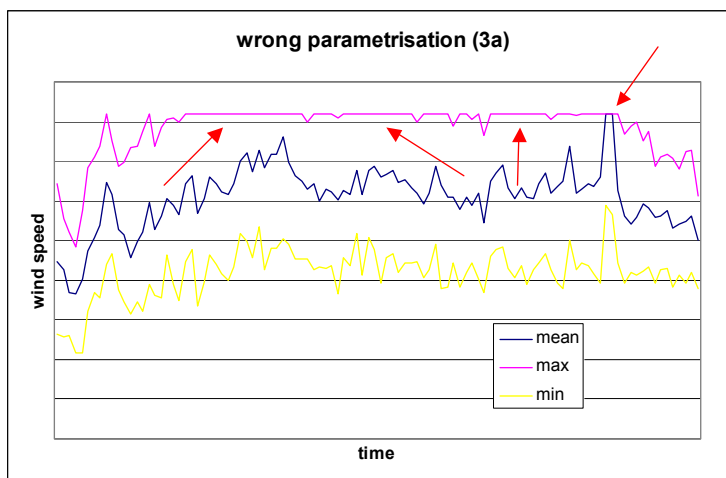

Figure 2: Consequence of wrong parametrisation of data logger

Another example of combined errors is icing of anemometers. It is mainly caused by weather, but naturally, this is out of human influence. The technical reason creating this error can be the absence of an anemometer's heating: sometimes icing is neglected in the design phase. In other cases heating is installed but not working, due to a failure of the anemometer itself or an installation error. Figure 3 shows the effect of icing on anemometers (blue, purple and light blue curve). The icing causes the temporary blockage of the sensors (marked by red arrows). All anemometers were installed at the same mast.

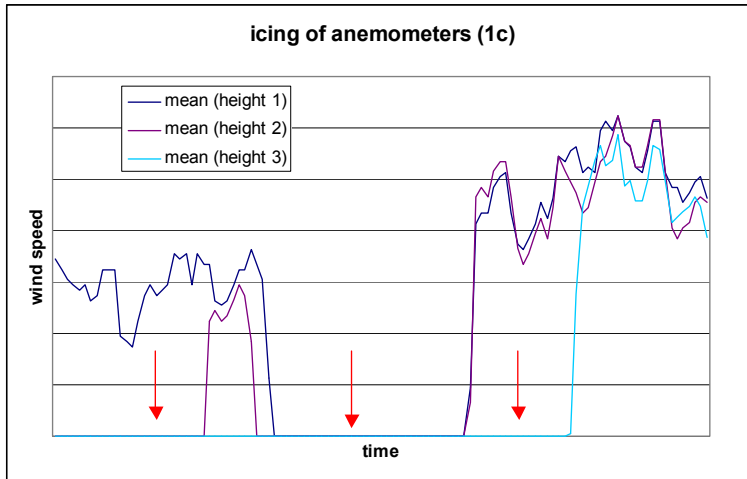

Figure 3: Consequence of icing on anemometers

Apparently, the effects of the combined errors can be manifold. But, how often do those errors occur? In this analysis, only technical errors were considered for their frequency of occurrence. As shown in Fig. 4 some classes of errors are dominating. To give a representative impression the frequencies were normalized to a sample station having one anemometer, one wind vane and one logger.

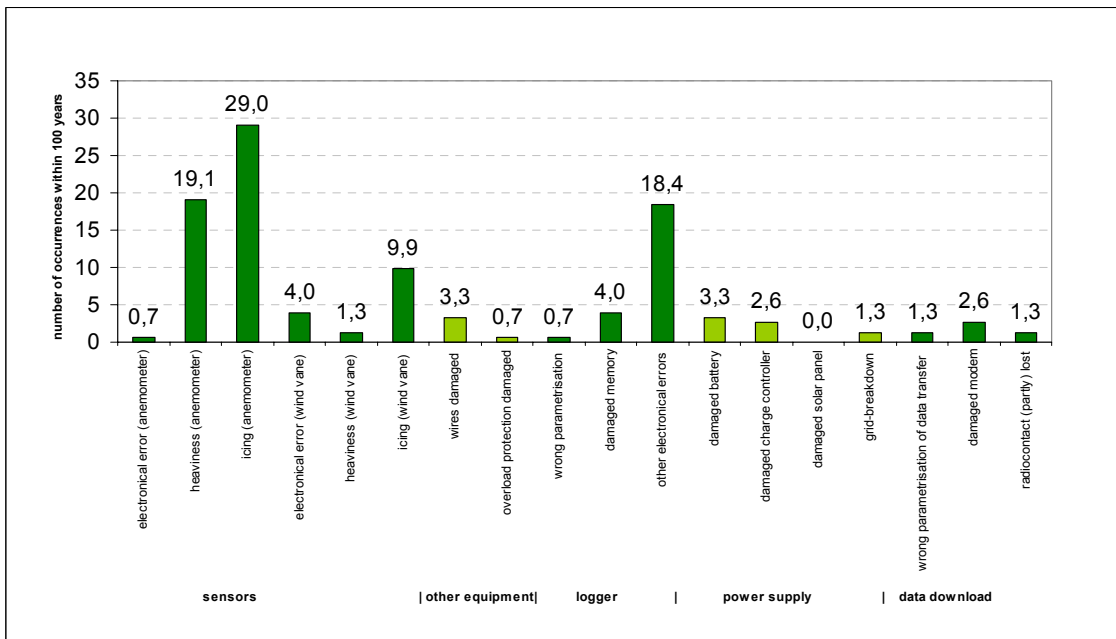

Figure 4: Mean frequency of occurrence of technical errors at the sample station

The error's frequency of occurrence expresses one aspect of the expectable risk caused by it. On the other hand, the influence of errors on the completeness of data is different: if the data are irrecoverable lost or modified, the causing error is severe. If the data are not lost or replaceable, it can be tolerable. It was tried to classify the error classes depending on their frequency and their severity as shown in table 2. Technical measures aiming efficient improvements of the data completeness should regard both factors.

severity code	severe	4c	1a;1e;2b;3a;4d;5a	1d;2a;3b;4a;4b;5b	1b;3c
	tolerable		5c	1f	1c
		not observed	low	medium	high
		frequency of occurrence			

Table 2: Error classification by frequency and severity

3 Technical measures for the avoidance of data losses

In order to avoid data losses due to technical failures, the following measures have to be considered when designing and manufacturing wind measurement systems:

The measurement system must be protected against external hazardous influences. Multi-level overvoltage protection modules protect data logger, modem, power supply and sensors against lightning and electrostatic discharge (see Fig. 5). Heated wind sensors provide gapless data even under icing conditions. Solar module and backup battery must be dimensioned for worst case conditions at the measurement site.

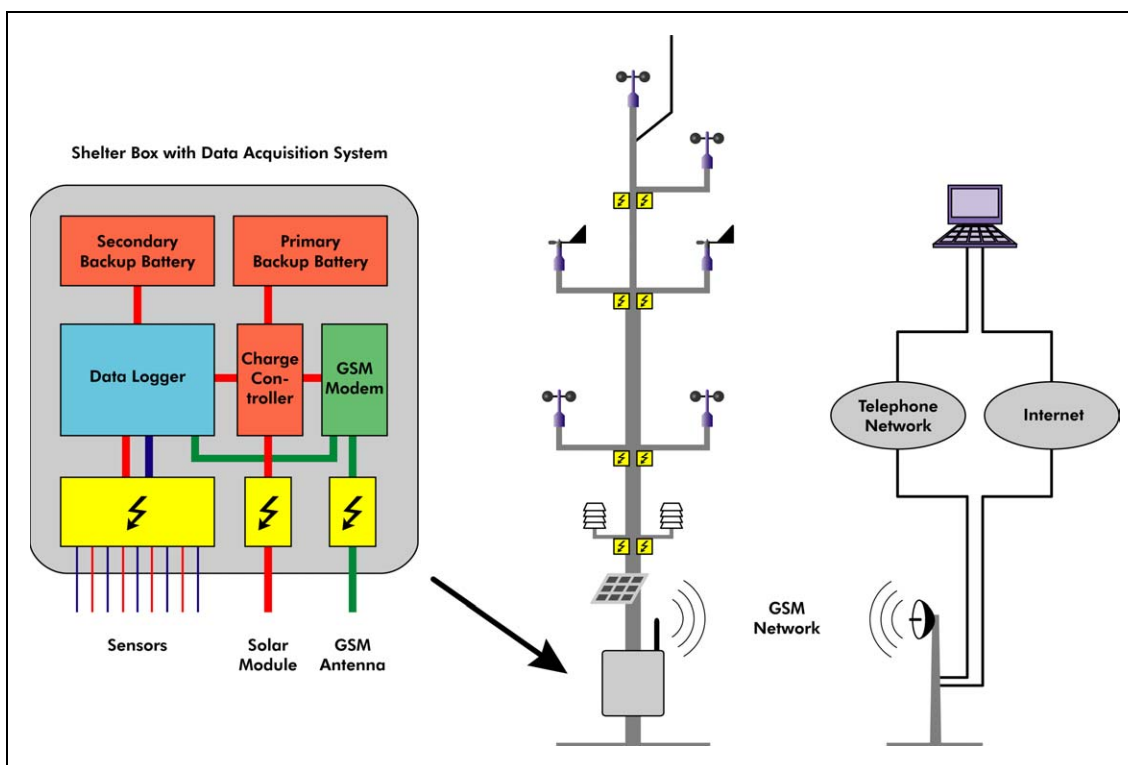

Figure 5: Design of a failure-resistant wind measurement system

Every wind measurement system must be tested with all its components and in the final configuration by the manufacturer. In order to improve the reliability of the measurement all measuring inputs of the data logger should be calibrated.

If an expectable and severe failure cannot be prevented, redundant components are able to ensure a “self repair” of the measurement system in case the error occurs. E.g., in case of a failure of the primary power supply a secondary backup battery ensures continuous operation of vital components like data logger and sensors. Measured data from redundant sensors can substitute data gaps from defective sensors.

Occurrence of errors should be made known to the operator as soon as possible. For this purpose the data logger should perform self checks. Measured data as well as error messages can be sent automatically via e-mail or FTP. Real-time access to the measurement station via GSM or Internet ensures direct control of the measurements at any time. Postprocessing of measured data via graphical tools or filter algorithms detect suspicious patterns such as icing or sensors failures. To put it in a nutshell: for some applications, a “condition monitoring system” for wind measurements is useful.

4 Documentation of wind measurements

A gapless and plausible time row will always facilitate its analysis – but it is not the complete measurement result. Further information has to be considered during the analysis of the data, but their documentation is neglected sometimes.

What information has to be collected to make a wind measurement understandable, even after the equipment’s dismantlement? Recommendations concerning the documentation of meteorological measurements in general have already been published a few years ago (among others, see [3]), but special aspects of wind resource measurements are not represented enough in detail. During the last few years, recommendations and standards covering this special case were published to give thorough guidelines ([4],[5]). An existing documentation in conformity with these papers guarantees that no information essential for the result has remained undocumented.

Implementation of these standards is, in 1st order, to be understood as a requirement on the organization of the measurement campaign. Responsibilities and authorities concerning the documentation have to be regulated in the preparation state, especially if several parties are involved. Most of the technical and site related information can and shall be collected in connection to the installation of the measurement set-up, but never later than it’s dismantlement. Events occurring during the measurement period are to be thoroughly collected in a station logbook, if they can be relevant for the result. This includes regular data uploads, irregularities and reparations at the measurement set-up as well as changes of the environment of the measurement site (e.g. new buildings etc.).

The maintenance of the logbook, the upload and storage of the measured data and the complete documentation should be managed using one integrated software system. All information relevant for the measurement (e.g. site info, serial numbers, measurement heights, sensor characteristics, parameter settings, observations etc.) should be stored in connection with the data. As good as the time rows produced by the wind measurement are normally computer files, the station’s documentation can be performed without paper documents, too. Finally, a wind measurement that is completely documented on data files makes flexibility and speed of modern communication via e-mail or Web available for the results of wind measurements.

5 References

- [1] IEA – Recommendations “Recommended practices for wind turbine testing and evaluation, part 11: Wind speed measurement and use of cup anemometry”, 1. edition 1999
- [2] IEC 61400-12 “Wind turbine generator systems, Part 12: wind turbines power performance testing”, 1. edition 1998-02
- [3] VDI 3786 “Environmental Meteorology – Meteorological Measurements, Part 1: Fundamentals”, edition November 1995
- [4] Recommendations for the documentation of wind measurements in the context of assessment of energy resource for wind energy projects; German wind energy association; Advisory board for wind resource; 1. edition 2003-09-25
- [5] Standard for the preparation of wind energy assessments; German wind energy association; Advisory board for wind resource; 2. edition 2005-02